

H-60 Production Cradle Fixture

Allows Transport of Partially Disassembled Structures

Note: H-60 refers to all versions of the Blackhawk Series Helicopters

Model No. 70600

Another Proprietary ADC Product

Fixture Features

- *Sturdy, Steel Square Tub Structure*
- *Casters and Jack Stabilizers*
- *Tow Bar Connector*
- *Interchangeable Jack Assemblies*
- *485 Bulkhead Hard Locators*
- *Removable Aft Cart Assembly*
- *Optional Position Butt Line Support*
- *Nylon Strap Down features*
- *Corrosion Resistant*

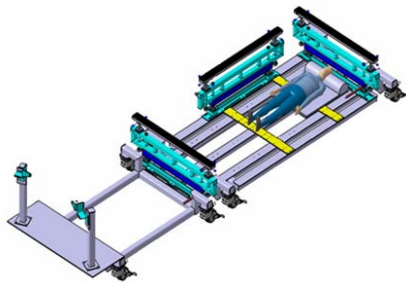

www.adceng.com

Jack Support Locations

Bulkhead Stations

Station 237.0
Station 247.0
Station 265.0
Station 295.0
Station 308.0
Station 325.5
Station 343.0
Station 363.0
Station 369.0
Station 379.0

Butt Line Locations

BL +30, -30
BL +10, -10
BL 0

Purposes of the H-60 Production Cradle

The functions of this fixture are to provide the following capabilities:

- *Allows valuable work cell area to be used by multiple disassembled H-60s*
- *Elevates and stabilizes the H-60 Airframe*
- *Levels the Airframe for Maintenance Operations*
- *Provides Under Fuselage Work Area accommodations*
- *Secures Partially Disassembled (unstable) Structures for relocation*
- *Provides for Tug Attachment*
- *Casters with Jack Stabilization Features*
- *Multiple Bulkhead and Butt Line Support Options*
- *Allows for removal of Aft Cart Assembly for addition work area access*
- *Provides a storage device for partially disassembled H-60s*

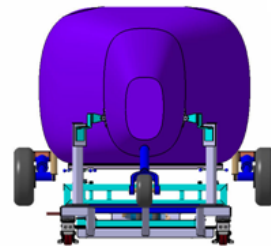
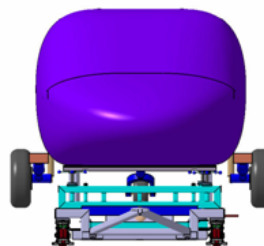
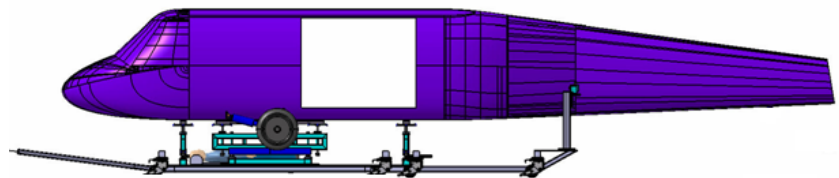

CRADLE FIXTURE ~ Major Assemblies

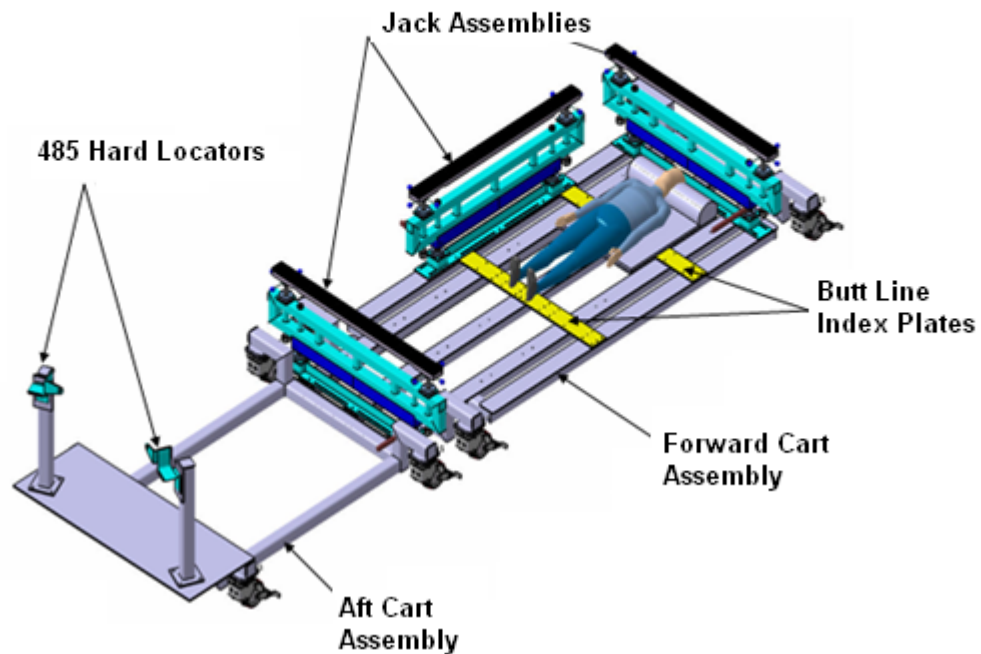

www.adceng.com

JACKING ASSEMBLY ~ Components

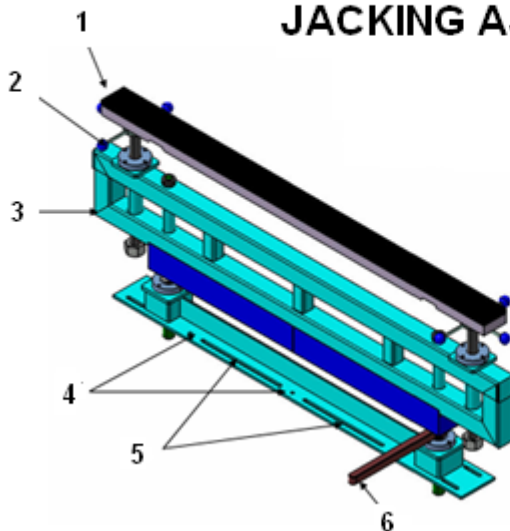

1. Padded Support Bar
2. Speed Hand Bar Raiser
3. Aluminum Welded Structure
4. Indexing Holes for Station Positioning
5. Slot for Indexing Positions for Butt Lines 0, 10, 30 ~ L&R Sides
6. Ratchet Lift System

